

MarathonTM TELESCOPIC HOIST



- *To 47-Ton Capacity.*
- *Maintenance-free cylinder pivots.*
- *Trunnion mount provides solid stability.*



CRYSTEEL



Building the World's Best Truck Bodies & Hoists

Crysteel's Marathon provides Power, Performance, and Endurance

The Marathon Telescopic Hoist offers powerful lifting action while minimizing wasted doghouse space for maximum hauling capacity. Plus, because the Marathon is trunnion-mounted, its stability is unmatched by conventional top pinned telescopic hoists.

Smooth acting final stages finish the job to a minimum 50° dump angle. High pressure maintenance-free twin lip seals never need adjusting. Built-in wipers keep the cylinder surface and seals clean and free of dirt, grit, and dust build-up.

Floating Cradle

Crysteel's Floating Cradle is designed to reduce the bending stress levels



between the truck frame and dump body frame that occur when a truck is traveling over uneven terrain. The Floating Cradle allows the hoist cylinder to pivot up to 2.5 degrees side to side reducing this bending tension. The Crysteel Floating Cradle is specially designed for haulers that move in and out of construction and demolition sites, gravel pits, and mining operations.

Excellent Stability

Because the Marathon's body and truck pivots are only a few inches apart, and because the Marathon lifts directly from the body's longitudinals, body twist and leaning are minimized for excellent stability.

Eight Models

The Marathon Hoist is available in eight models for dump bodies 9 to 21.5 feet (or longer with less than 50° dump angle) for load capacities from 24 to 47 tons.

Add Crysteel's quality hydraulics and full warranty—the industry's best—and you have the most dependable telescopic hoist on the market.



Crysteel Marathon's ingenious body mount lifts directly on the longbeams for efficient power delivery and superior stability, throughout the dump cycle.



Quality Performance Features



- Cylinder pivots on maintenance-free, greaseless composite Teflon® bearings.
- Reinforced lower cylinder tube and full-width angle hinge help ensure stability.
- Single-lever locking shifter with sealed cable.
- Reservoirs have sight gauge for easy visual inspection.



Optional Features

- Double-acting cylinders.
- Dual-lever control with sealed cable.
- Hard chrome-plated cylinder surface.
- Air shift control.
- Remote-mount bracket with drive-line kit for pump.
- Remote-mount valve with power beyond capabilities.
- Full-length subframe.
- Removable pin and/or composite bearing rear hinges.
- Remote underbody stabilizer.
- Less hydraulics.
- Return line filter kit.
- "Body up" indicator light kit.



High Performance Crysteel Hydraulics



- Oversized hydraulic hoses keep cycle time fast.
- O-ring ports keep connections leak-free for years of trouble-free service.
- Direct-mount gear pump/valve combination for easy installation.
- Large seals and wipers seal out grit and never need adjusting.
- 2500 psi-rated cylinders match up easily with your central hydraulic system.

Cylinder Retracts

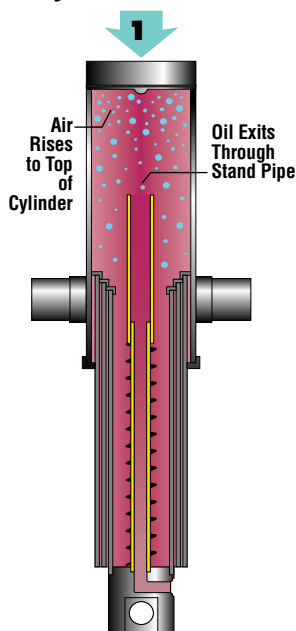

Cylinder Nears End of Stroke

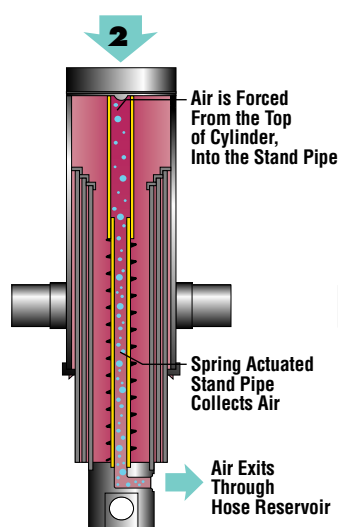

Cylinder Retracted

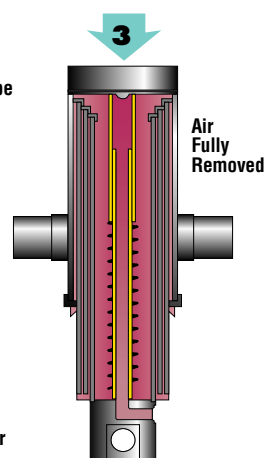

Auto-Bleed™ Cylinders

Crysteel's patented AUTO-BLEED™ cylinders eliminate the inconvenience and dangers of manually bleeding air out of your cylinder. The AUTO-BLEED system **automatically** and **effortlessly** removes unwanted air from the hydraulic system safely and cleanly. Marathon hoists with the patented AUTO-BLEED system set a new **standard of excellence** in the truck hoist industry.

Patent Numbers
 US 5,390,586
 Canada 2,142,374
 Mexico 185,833

MARATHON HOIST SPECIFICATIONS

	M5390	M5399	M53117	M63138	M63153	M74161	M74181	M74201
NTEA Performance Class	70	70	80	120	120	110	110	110
Number of Stages	3	3	3	3	3	4	4	4
Active Stage Sizes (in.)	5, 4, 3	5, 4, 3	5, 4, 3	6, 5, 4	6, 5, 4	7, 6, 5, 4	7, 6, 5, 4	7, 6, 5, 4
Total Stroke (in.)	90	99	117	138	153	161	181	201
Cylinder Rated Pressure (PSI)	2500	2500	2500	2500	2500	2500	2500	2500
Cylinder Style	Inverted	Inverted	Inverted	Inverted	Inverted	Inverted	Inverted	Inverted
Std. Pump GPM @ 1000 RPM	10	15	15	20	20	25	25	25
Std. Reservoir Type	Outside Frame	Outside Frame	Outside Frame	Outside Frame	Outside Frame	Doghouse	Doghouse	Doghouse
Std. Reservoir Size (gal.)	16	16	23	28	28	30	30	30
Recommended Body Length (ft.)*	9-10.5	11-11.5	12-13.5	14-15.5	16-16.5	16-17.5	18-19.5	20-21.5
Floor Height (inches)	8	8	8	8	8	8	8	8
Approximate Weight (lbs.)	650	690	780	890	950	1050	1100	1150

MARATHON HOIST LOAD CAPACITY IN TONS*

Marathon Model	NTEA Class	Body Length (ft.)												
		9	10	11	12	13	14	15	16	17	18	19	20	21
M5390	70	36.8	29.8											
M5399	70			27.5										
M53117	80				28.3	24.9								
M63138	120						46.4	42.0						
M63153	120								41.8					
M74161	110									47.0	43.9			
M74181	110											46.3	43.6	
M74201	110													45.7 43.3

Specifications subject to change.

*Capacities based on water-level load, 12" overhang, 50° dump angle, and includes body weight.

CAUTION: The combined weights of truck, body, hoist and load must not exceed the truck's Gross Vehicle Weight rating.



CRYSTEEL MANUFACTURING, INC.

52182 Ember Road • Lake Crystal, MN • 56055 & 1902 Rt. 57 South • Fulton, NY • 13069

1-800-533-0494 • 1-507-726-2728 • FAX 1-507-726-2559 • Internet <http://www.crysteel.com> • e-mail crysteel@crysteel.com

Sold by: